

**GRAND COUNTY, UTAH
ORDINANCE 588 (2019)**

**APPROVING OUTDOOR LIGHTING AND
SIGN ILLUMINATION STANDARDS**

WHEREAS, the Grand County Council (County Council) adopted the *Grand County General Plan Update* (General Plan) on February 7, 2012 with Resolution No. 2976;

WHEREAS, the County Council adopted the *Grand County Land Use Code* (Land Use Code or LUC) on January 4, 1999 with Ordinance No. 299 and amended it February 19, 2008 with Ordinance No. 468 for the purpose of regulating land use, subdivision and development in Grand County in accordance with the General Plan;

WHEREAS, Sections 2.11.4, 6.5.5(D), and 6.6 of the Grand County LUC address outdoor lighting and sign illumination standards;

WHEREAS, Grand County acknowledges the relationship between land development, urban design, and potential impacts on dark skies;

WHEREAS, the Utah Legislature adopted Senate Concurrent Resolution (S.C.R.) 002 (2018), which encourages the use of shielded outdoor lighting to promote dark skies;

WHEREAS, backlight, uplight, and glare creates wasted light, excessive light, light pollution, and light trespass into unwanted areas;

WHEREAS, light pollution is the artificial brightening of the night sky due to light that escapes from poorly designed light fixtures;

WHEREAS, property owners and the County could reduce their power costs by discontinuing the use of unshielded light fixtures;

WHEREAS, humans and wildlife rely on the earth's daily cycle of light and dark, and research suggests that light pollution has a negative effect on sleep cycles;

WHEREAS, light pollution negatively impacts professional and amateur astronomers who rely on the darkness of skies to observe, study, further scientific knowledge, and generally enjoy the regional environment;

WHEREAS, many residents of an visitors to the Moab Area are attracted by the relatively pristine dark skies in the region and throughout the Colorado Plateau;

WHEREAS, in a public hearing on January 8, 2019, the Grand County Planning Commission considered all evidence and testimony presented with respect to the subject application and forwarded a favorable recommendation to the Grand County Council;

WHEREAS, due notice was given that the Grand County Council would meet to hear and consider the proposed ordinance establishing new sign illumination and outdoor lighting standards in a public hearing on March 19, 2019;

WHEREAS, the County Council has heard and considered all evidence and testimony presented with respect to the subject application and has determined that the adoption of this ordinance is in the best interests of the citizens of Grand County, Utah;

NOW, THEREFORE, BE IT ORDAINED by the County Council that the LUC is hereby amended to read:

See Exhibit A

PASSED, ADOPTED, AND APPROVED by the Grand County Council in open session this April 2, 2019 by the following vote:

Those voting aye: Halliday, Hawks, McGann, Morse, Wells, Clapper

Those voting nay: _____

Those abstaining: Paxman

ATTEST:



Chris Baird, Clerk/Auditor

Grand County Council



Evan Clapper, Chair

Exhibit A

Outdoor Lighting and Sign Illumination Standards

Section 2.11.4 (Resort Commercial District)

F. Signage

All signs shall comply with the requirements of Section 6.5.

Section 6.5.5(D) Permitted Signs Illumination

1. Signs may be unlighted, lighted externally, lighted internally, or backlit. All sign lighting must be designed, directed, and shielded in such a manner that the light source is not visible beyond the property boundaries where the sign is located. Lighting for signs must be directed such that only the sign face is illuminated. All lighted signs must have stationary and constant lighting. All sign lighting is included in the calculation of total light output for a property.
 - a. Standards for Externally Illuminated Signs:
 1. Lighting for externally illuminated signs must be aimed and shielded so that light is directed only onto the sign face and does not trespass onto adjacent streets, roads or properties or into the night sky.
 2. Lighting for externally illuminated signs must be mounted at the top of the sign (or within 2 feet of the top of a wall mounted sign), except for freestanding monument style signs which may be illuminated by ground mounted lighting.
 3. Lighting shall consist of no more than four (4) individual fixtures (or lamps) per sign face and produce a maximum of 40,000 lumens per fixture.
 4. All sign lighting shall be included in the calculation of total light output.

Permitted and Prohibited External Sign Lighting Configurations	
Allowed	Not Allowed

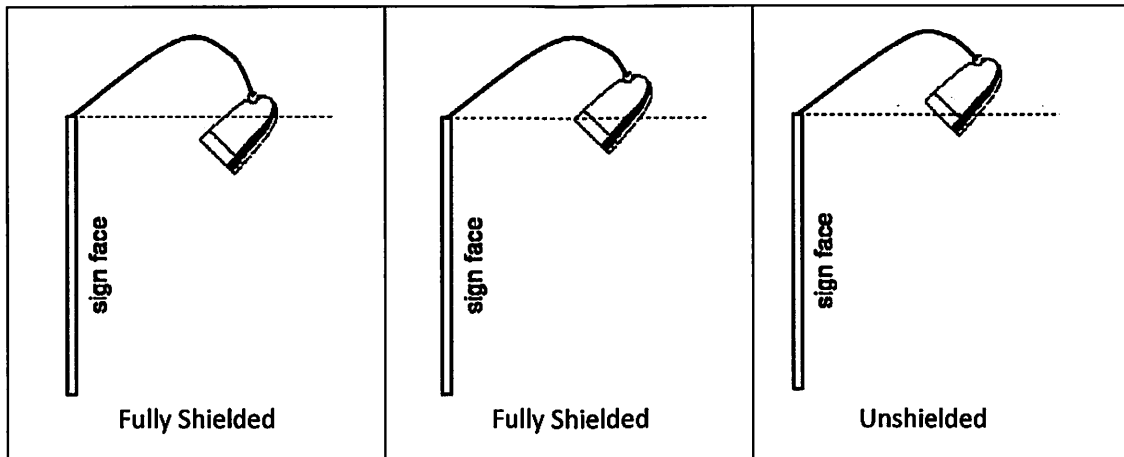

b. Standards for Internally Illuminated Signs:

1. Only sign text areas and logos may be illuminated on an internally illuminated sign.
2. Internally illuminated signs shall use semi-opaque materials for sign text and logos such that the light emanating from the sign is diffused. Transparent or clear materials are not allowed for sign text and logos. Non-text portions of the sign (e.g., background and graphics other than the logo) shall be made of completely opaque material.

c. Standards for Backlit Signs:

1. The light source shall not be visible.
2. Backlit signs shall only allow indirect illumination to emanate from the sign. For example, signs that create a "halo" effect around sign copy are allowed.

d. Standards for Illuminated Window Signs

1. Businesses may display a maximum of two (2) illuminated window signs positioned to be primarily visible outside the business structure.
2. Illuminated window signs shall not exceed four (4) square feet in area.
3. Illuminated window signs shall not be illuminated when the business is closed.

Section 6.6 – Outdoor Lighting

6.6.1 Purpose

The Purposes of this Section are to:

- A. Encourage outdoor lighting practices that will minimize light pollution, glare, light trespass and sky glow to curtail the degradation of the night time visual environment;

- B. Prevent lighting nuisances on properties located in and adjacent to Grand County;
- C. Promote energy conservation;
- D. Improve night-time safety, utility, security, and productivity;
- E. Develop an attractive nighttime appearance in the County;
- F. Minimize lighting health risks arising from inappropriate quantities and qualities of lighting;
- G. Prevent unnecessary or inappropriate outdoor lighting;
- H. Minimize nighttime impacts on nocturnal wildlife;
- I. Facilitate the economic development potential of astro-tourism, and the enhancement of the visitor experience in the Moab Area;
- J. Maintain the rural atmosphere of the County; and
- K. Encourage quality outdoor lighting through the use of efficient bulbs and light sources, fully shielded light fixtures, and limits on the location and uses of outdoor lighting.

6.6.2 Scope and Applicability

- A. All lighting should be consistent with and promote the Purposes set forth in Section 6.6.1.
- B. All exterior outdoor lighting installed after the effective date of this section in all zones in the County shall conform to the requirements established by this section. This Section does not apply to indoor lighting.
- C. All existing outdoor lighting that does not meet the requirements of this Section and is not exempted by this Section shall be considered a nonconforming use or part of a nonconforming structure subject to the five (5) year amortization schedule outlined in Section 6.6.10(B)(3) of this LUC.

6.6.3 Definitions

“Accent or Architectural Lighting” means lighting of building surfaces, landscape features, statues, and similar items for the purpose of decoration, ornamentation, creation of visual hierarchy, sense of liveliness, or other purpose unrelated to safety, business operation, or essential lighting function.

“Backlight” means all the light emanating behind a luminaire.

“B.U.G. Rating” means backlight, up-light, and glare rating, which exists on a scale of zero to five (0 to 5) and describes the light output of a luminaire.

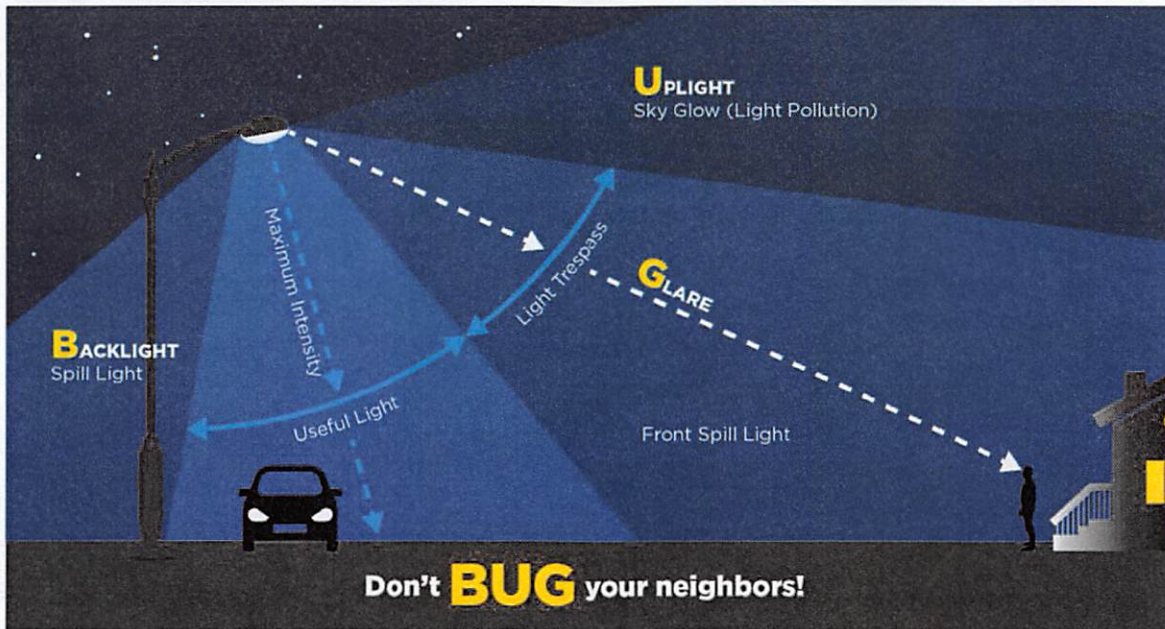

Image by City of Ft. Collins, Colorado and used here with permission.

“Correlated Color Temperature” (CCT) is a specification of the color appearance of the light emitted by a lamp, relating its color to the color of light from a reference source when heated to a particular temperature, measured in degrees Kelvin (K). The CCT rating for a lamp is a general "warmth" or "coolness" measure of its appearance. Lamps with a CCT rating below 3,000 K are usually considered "warm" sources, while those with a CCT above 3,000 K are usually considered "cool" in appearance.

“Direct Illumination” means illumination resulting from light emitted directly from a bulb, luminary, or reflector. This does not include light reflected from other surfaces such as the ground or building faces.

“Fixture” means a complete lighting unit consisting of a lamp or lamps together with the parts designed to distribute the light, to position and protect the lamps, and to connect the lamps to the power supply.”

“Floodlight” means a fixture or bulb designed to "flood" an area with light. A specific form of bulb or fixture designed to direct its output in a specific direction. Such bulbs are often designated by the manufacturer and are commonly used in residential outdoor lighting.

“Fully Shielded Fixture” means an outdoor light fixture constructed and mounted so that the installed fixture emits no light above the horizontal plane. Where a light manufacturer provides a BUG rating, the uplight rating (U) must equal zero (0). Fully shielded light fixtures must be shielded in and of themselves. Surrounding structures, like canopies, are not to be considered when determining if the fixture is fully shielded. Fully shielded fixtures must be appropriately mounted so that the shielding prevents light from escaping above the horizontal and all light is directed downward.

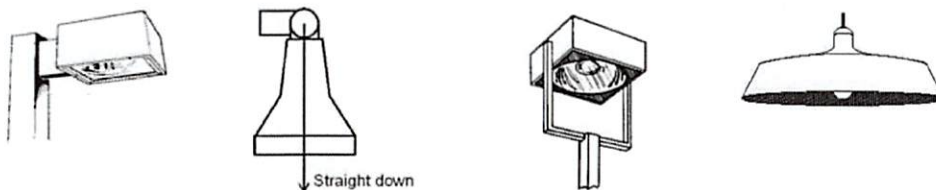

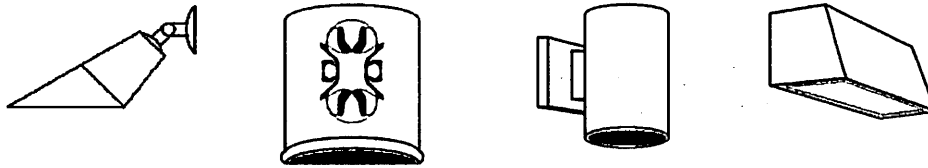

Examples of fully shielded light fixtures.

“Glare” means the visual sensation caused by excessive brightness and which causes annoyance, discomfort, or a disability loss in visual performance or visibility.

“Internally Illuminated” as it relates to signs, means any sign which has a light source entirely enclosed within the sign and not directly visible to the eye.

“Light Pollution” means any adverse effect of manmade light. Often used to denote "sky glow" from developed areas, but also includes glare, light trespass, visual clutter and other adverse effects of lighting.

“Light Source” means the part of a lighting fixture that produces light, e.g. the bulb, lamp, or chips on board.

“Light Trespass” means any light that falls beyond the legal boundaries of the property it is intended to illuminate.

“Lumen” means a unit of luminous flux equal to the light emitted by a uniform point source of one candle intensity. Lumens refers to the amount of light emitted by a bulb (more lumens equals brighter light).

Common Relationships between bulb types, wattages and lumen levels

Brightness in Lumens	220+	400+	700+	900+	1300+
Standard	25W	40W	60W	75W	100W
Halogen	18W	28W	42W	53W	70W
CFL	6W	9W	12W	15W	20W
LED	4W	6W	10W	13W	18W

“Luminaire” means the same as “fixture.”

“Manufacturer’s Catalog Cuts” means a publication or other printed material of a bulb or lighting manufacturer offering visual and technical information about a lighting fixture or bulb.

“Developed Acre” means the proportionate amount of an acre (43,560 square feet) of land that is converted from raw, undeveloped land into land associated with the permitted principal and accessory uses occurring on a parcel. This includes building footprints, private roads, parking lot surface areas, designated recreational areas, walking paths, stormwater detention and retention facilities, and other lands clearly related to the permitted uses on a parcel. Present and future public rights-of-way, lands with natural slopes greater than 30 percent, jurisdictional wetlands, lands in the 100 year floodplain, public drinking water supply water sources (recharge areas for the aquifer in the Glen Canyon Formation), lands affected by immitigable geo-hazards, riparian habitats, archeological sites, and required open space shall not be included in the calculation of developed acreage.

“Outdoor Light Fixture” means a complete lighting unit consisting of a lamp(s) and ballast(s) (when applicable), together with the parts designed to distribute the light, to position and protect the lamps, and to connect the lamps to the power supply. Also known as a luminaire, or simply as a fixture.

“Partially Shielded Light Fixture” means an outdoor light fixture constructed and mounted so that the installed fixture emits most of its light above the horizontal plane. Where a light manufacturer provides a BUG rating, the

uplight (U) and backlight (B) ratings are greater than zero (0). Light emitted at or above the horizontal plane (sideways or upwards) shall arise solely from incidental decorative elements or strongly colored or diffusing materials such as colored glass or plastic. Fixtures using spot or flood lamps are considered partially shielded if the lamps are aimed no higher than 45 degrees above the vertical plane beneath the fixture.

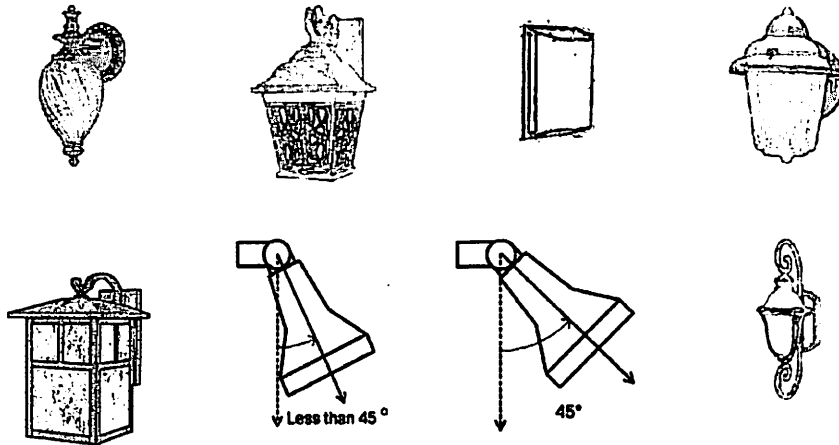

Examples of partially shielded lighting fixtures

“Recreational Lighting” means lighting used to illuminate sports fields, ball courts, playgrounds, or similar outdoor recreational facilities.

“Skyglow” means the brightening of the nighttime sky resulting from the scattering and reflection of artificial light by moisture and dust particles in the atmosphere. Skyglow is caused by light directed or reflected upwards or sideways and reduces one’s ability to view the nighttime sky.

“Spotlight” means a fixture or bulb designed to light a small area very brightly. See definition of Floodlight.

“Total” means the sum of shielded and unshielded light.

“Total outdoor light output” means the total amount of light measured in lumens from all bulbs installed in outdoor lighting fixtures. For bulb types that vary in light output as they age (such as fluorescent and high intensity discharge (HID) bulbs), the initial lumen output as defined by the manufacturer shall be the lumen value used.

“Tower” means any monopole, antenna, or the like that exceeds eighteen feet (18') in height.

“Unshielded Fixture” means a fixture that has no shielding at all that would otherwise specifically prevent light emission above the horizontal.

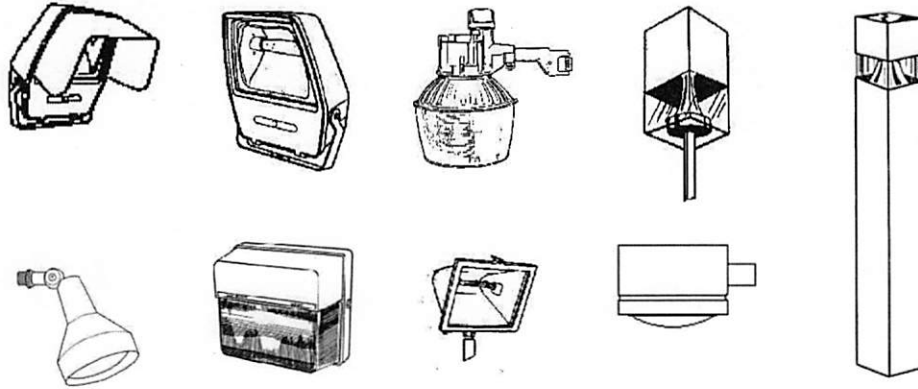

Examples of unshielded light fixtures.

“Uplight” means all the light emanating above the horizontal plane of a luminaire.

6.6.4 Fully Shielded Fixture Requirements

- A. Unless specifically exempted by this Section, all outdoor lighting shall use fully shielded fixtures and shall be installed so light is directed downward with no light emitted above the horizontal plane of the fixture. Where a light manufacturer provides a BUG rating, the uplight rating (U) must equal zero (0).
- B. In order to qualify as a "fully shielded" fixture, a light fixture must have the top and sides made of completely opaque material such that light only escapes through the bottom of the fixture. Fixtures with translucent or transparent sides, or sides with perforations or slits, do not qualify as fully shielded. Any glass or diffuser on the bottom of the fixture must be flush with the fixture (no drop lenses). Merely placing a light fixture under an eave, canopy, patio cover, or other similar cover does not qualify as fully shielded.
- C. Fixtures must not be placed at a location, angle, or height that directs illumination outside the property boundaries where the light fixtures are located.
- D. Notwithstanding the exemptions in Section 6.6.4.E, all residential and commercial luminaires shall be fully shielded within twenty-five (25) feet of adjacent residential property lines.
- E. Exemptions to Fully Shielded Fixture Requirements:
 - 1. All lights exempted by this section shall be included in the calculation for total light output.
 - 2. Fixtures having a total light output less than one thousand (1,000) lumens are exempted from the fully shielded requirement provided the following criteria are met:
 - a. The fixture has a top that is completely opaque such that no light is directed upwards.
 - b. The fixture has sides that completely cover the light source and are made of opaque or semi-opaque material. Fixtures with opaque sides may have incidental decorative perforations that emit small amounts of light. Semi-opaque material such as dark tinted glass or translucent plastic may be used if the light source is not discernable behind the material. Completely transparent materials, such as clear or lightly tinted colored glass, are not allowed.
 - c. The light source must not be visible from any point outside the property on which the fixture is located.

3. Spotlights controlled by motion sensors having a light output less than one thousand (1,000) lumens per lamp are exempted from the fully shielded requirement provided:
 - a. The fixture is a spotlight or other type of directed light that shall be directed straight down; and
 - b. The fixture must not be placed in such a manner that results in illumination being directed outside the property boundaries where the light fixtures are located.
 - c. Lights controlled by motion sensors shall not be triggered by movement or activity located off the property on which the light is located.
4. Pathway lights less than eighteen inches (18") in height are exempted from the fully shielded fixture requirement, if the total light output from each pathway light is less than three hundred (300) lumens.
5. Temporary exterior lighting intended as holiday or seasonal decorations displayed between November 15 and the following January 15, provided that individual lamps do not exceed 70 lumens and neither cause light trespass nor interfere with the reasonable use and enjoyment of any other property.
6. Traffic control signals and devices.
7. Temporary emergency lighting in use by law enforcement or government agencies or at their direction.
8. The lighting of federal or state flags, provided that the light is a top-down and narrow beam aimed and shielded to illuminate only the flag.
9. An applicant requesting approval for lighting that does not conform to these standards shall follow the procedures and findings requirements set forth in Section 9.14 Variances.

6.6.5 Total Light Output

- A. Commercial. Total outdoor light output shall not exceed fifty thousand (50,000) lumens per developed acre. Streetlights used for illumination of public rights-of-way are excluded from this calculation. Commercial developments shall be permitted a minimum of 5,000 lumens of lighting regardless of parcel size.
 1. In non-residential zone districts, partially and unshielded lighting on a property shall not exceed 5,000 lumens per developed acre, and shall be included in the total outdoor light output calculation
- B. Residential. Total outdoor light output shall not exceed ten thousand (10,000) lumens of lighting for parcels one-half (acre), or larger, in size. Parcels smaller than one-half (1/2) acre shall be permitted five thousand (5,000) lumens of lighting regardless of parcel size. Total outdoor light output of any multifamily residential development including five (5) or more separate lots or units shall not exceed twenty thousand (20,000) lumens of lighting per developed acre.
 1. In residential zones, partially and unshielded lighting on a property shall not exceed 1,000 lumens per lot, and shall be included in the total outdoor light output calculation.

2. Residential units used for overnight accommodations or other commercial uses shall comply with the residential standards for total light output.

6.6.6 Lighting Hours

- A. Commercial establishments shall turn off all outdoor lighting, except that listed below, by twelve o'clock (12:00) midnight:
 - a. Businesses open to the public after twelve o'clock (12:00) midnight may leave all outdoor lighting on until one hour after the close of business.
 - b. Lighting to illuminate the entrance to the commercial establishments.
 - c. Parking lot and pathway lighting required for the safety of guests or customers.
- B. Recreational lighting (residential and commercial) shall be turned off by ten o'clock (10:00) P.M. or one hour after conclusion of a specific sporting event, whichever is later.

6.6.7 Lighting Color

All exterior lighting shall utilize light sources with correlated color temperature not to exceed 3,000 Kelvin (K).

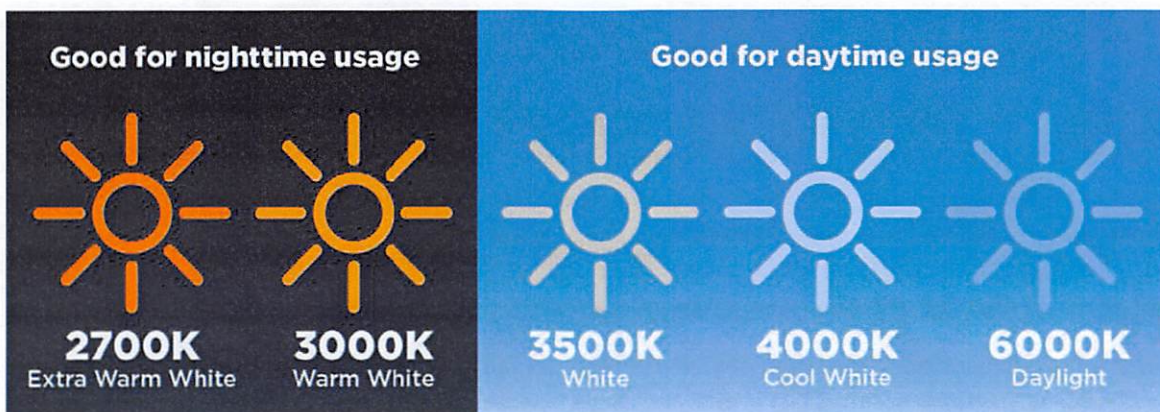

Image by City of Ft. Collins, Colorado and used here with permission.

6.6.8 Specialized Outdoor Lighting Conditions and Standards

- A. Gas station canopies may be illuminated provided all light fixtures are mounted on the undersurface of the canopy and all light fixtures are fully shielded. Merely placing the fixtures on the underside of the canopy does not qualify as fully shielding the light fixture.
- B. Roadway and street lights are prohibited unless recommended by the County engineer or required by UDOT to provide for the safety of the public. When deemed necessary, streetlights shall utilize lamp types that are fully shielded luminaires that minimize sky glow, light trespass, and other unintended impacts of artificial lighting. All streetlights shall utilize the lowest illuminance levels acceptable to the County engineer and UDOT.
- C. Parking lots may not utilize spot or flood lighting whether mounted on a post or exterior building wall. The overall height of any light post used to illuminate parking lots in commercial zones shall not exceed twenty-five feet (25'). All post mounted parking lot lights shall be set back from property lines a distance

equal to two and one-half (2.5) times the height of the pole unless an internal or external shield prevents the fixture being visible from outside the property boundaries. The overall height of any light post used to illuminate parking lots in residential zones shall not exceed twenty-five feet (25'). All parking lot lighting shall use fully shielded downward directed fixtures. Internal or external shields shall prevent the fixture being visible from outside the parking lots.

- D. Outdoor recreation areas or athletic fields at publicly owned facilities may use illumination to light the surface of play and viewing stands and for the safety of the public. The following standards shall apply to outdoor recreation area or athletic field lighting:
1. The recreational lighting does not exceed illuminance levels for class IV sports lighting set by the Illuminating Engineering Society of North America.
 2. The recreational lighting provides illuminance for the surface of play and viewing stands, and not for any other areas or applications.
 3. Off-site impacts of the lighting will be limited to the greatest practical extent possible
 4. The lighting for areas or applications outside the surface of play and viewing stands shall conform to all provisions in this Section.
 5. The recreational or athletic facility shall extinguish lighting exempted by this section no later than 10:00 pm or one hour after the end of play, whichever is later.
 6. The recreational lighting shall have timers that automatically extinguish lighting to ensure lights are not left on after the curfew or when the facilities are not in use.
- E. Outdoor amphitheatres may use illumination to light the performance area of the amphitheater and for the safety of the public. The following standards apply to all amphitheater lighting:
- a. Lighting used to illuminate the performance area must be either directed spotlighting or fully shielded lighting. If directed spotlighting, the light source must be located and designed such that it is not visible beyond the property boundaries.
 - b. Lighting used to illuminate the performance area may only be turned on during performances or rehearsals.
 - c. Lighting used to illuminate the seating areas, pathways, and other areas of the amphitheater must meet all standards of this Section.
- F. Special events may use illumination to light the event area and for the safety of the public. The following standards apply to all amphitheater lighting:
- a. Lighting used to illuminate the event area must be either directed spotlighting or fully shielded lighting. If directed spotlighting, the light source must be located and designed such that it is not visible beyond the property boundaries.
 - b. Lighting used to illuminate the event area may only be turned on during the hours event activities are open to the public or paying guests.
 - c. Lighting used to illuminate the seating areas, pathways, and other areas of the event must meet all standards of this Section.
- G. All illuminated signs shall comply with the standards of Section 6.5.

6.6.9 Application and Review Procedures

A. Lighting Plan

All sign permit applications, subdivision applications, site plan applications, building permit applications, and other development review applications within any zone district shall include a lighting plan that shows evidence that the proposed lighting fixtures and light sources comply with this code. Lighting plans shall include the following:

- 1. Plans or drawings indicating the proposed location of lighting fixtures, height of lighting fixtures on the premises, and type of illumination devices, lamps, supports, shielding and reflectors used and installation and electrical details.**
- 2. Illustrations, such as contained in a manufacturer's catalog cuts, of all proposed lighting fixtures. For commercial uses, photometric diagrams of proposed lighting fixtures are also required. In the event photometric diagrams are not available, the applicant must provide sufficient information regarding the light fixture, bulb wattage, and shielding mechanisms for the planning commission to be able to determine compliance with the provisions of this Section.**
- 3. A table showing the total amount of proposed exterior lights, by fixture type, wattage, lumens, and lamp type.**

B. Approval Procedure:

- 1. The lighting plan for all new development shall be submitted for approval concurrent with the associated application process.**
- 2. A certificate of occupancy shall not be issued until such time as the property is subject to a post installation nighttime inspection by the Planning and Zoning Administrator.**

6.6.10 Amortization of Nonconforming Outdoor Lighting

A. The County shall require the termination of use of any and all nonconforming outdoor lighting fixtures, structures, lamps, bulbs or other devices that emit or generate light which are not otherwise exempted by this Section, pursuant to the amortization schedule contained in this Section 6.6.10.B.

B. All outdoor lighting legally existing and installed prior to the effective date of this Section, and which is not otherwise exempted, shall be considered nonconforming and shall be brought into compliance by the property owner as follows:

- 1. Immediately as a condition for approval upon application for a building permit, sign permit, conditional use permit, new (nonrenewal) business license, site plan review or similar County permit or review.**
- 2. Immediately in the case of damaged or inoperative nonconforming lighting upon replacement or repair.**
- 3. Within five (5) years from the effective date of this Section for all other outdoor lighting.**

Additional Images:

Examples of Acceptable / Unacceptable Lighting Fixtures

Unacceptable / Discouraged

Fixtures that produce glare and light trespass

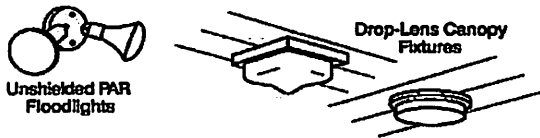
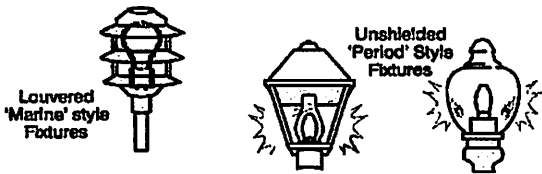
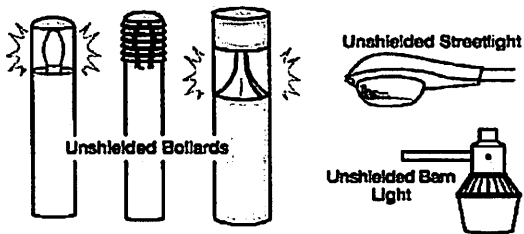
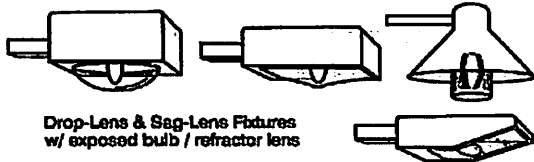
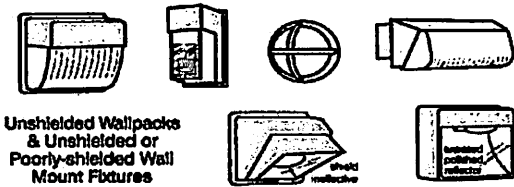
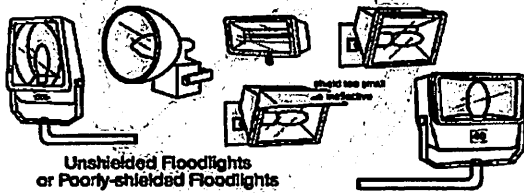

Acceptable

Fixtures that shield the light source to minimize glare and light trespass and to facilitate better vision at night

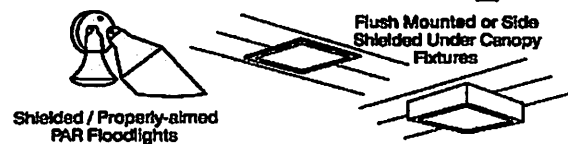
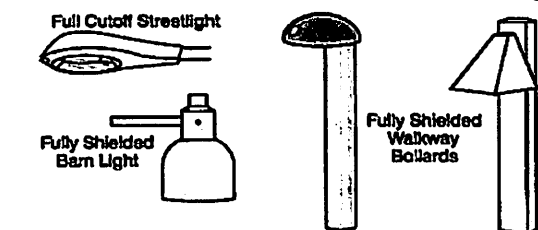
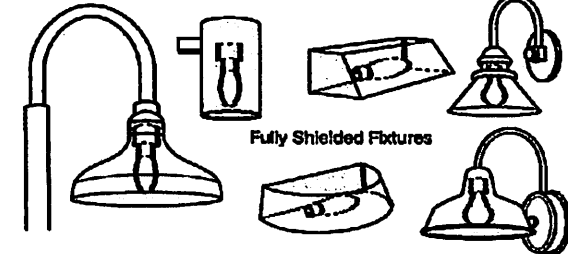
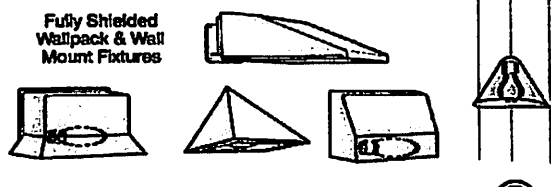
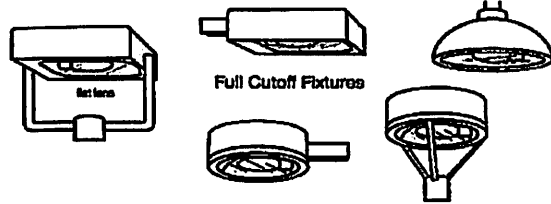

Illustrations by Bob Crelin © 2005. Rendered for the Town of Southampton, NY. Used with permission.

Used by premission

